



INSTALLATION INSTRUCTIONS

Thank you for purchasing SRT-2® Spool Roll Tarp. Agri-Cover, Inc. proudly manufactured this tarp using superior quality materials and workmanship. With proper care, your tarp will provide years of service.

NOTICE TO INSTALLER: Even if familiar with product, read instructions prior to installation as improvements may be made without notice. Always handle components with care. If you have questions or problems, have serial number ready and call customer service. When done, these instructions must be given to the consumer.

NOTICE TO CONSUMER: Before using this product, read operating, maintenance and safety sections. Save these instructions for future reference.

FOR YOUR RECORDS

DATE PURCHASED: _____

WHERE PURCHASED: _____

TARP SERIAL NUMBER: _____

(Located at rear of tarp on stationary tube side)



AGRI-COVER, INC.

Questions? (800) 233-4655
agricover.com

PREPARATION

- Prior to tarp system assembly, park truck or trailer on level ground.
- Box must be square and straight, center must not be pulled together or spread apart.
- Before beginning, measure outer length and width of your box. Also measure length of tarp and width of the end caps to ensure you received the correct size.
- Remove or grind smooth any sharp edges or points contacting tarp and/or cables.
- Remove or reposition any interferences with tarp. If modifications to box are needed, consult box manufacturer.
- It may be necessary to use washers and nuts or other types of fasteners (not furnished) to ensure a solid anchor.
- Ensure box extension is secure by bolting in place on top of your box.

TOOLS NEEDED

- 1/2", 9/16" and 3/4" Wrenches
- 3/16" Allen wrench
- Threadlock adhesive
- Step ladders or scaffolding
- Drill with 5/16" and 3/8" bits
- Tape measure
- Impact wrench with 9/16" socket
- Hammer
- Protective eyewear
- Cutting tool(s)
- Marking pencil

OPTIONAL TOOLS NEEDED

- Liner tool
- Clamps
- Heat source

NOTE: Hardware appearance and components may vary.

▲ CAUTION: Before drilling, ensure there are no hidden wires or gussets in line with holes to be drilled.

STAINLESS STEEL ONLY

▲ CAUTION: To avoid galling of stainless steel hardware, use anti-galling spray, grease or lubricant on threads and avoid high speed when fastening. Do not use impact tools for stainless steel hardware.

3/8" x 1" non-stainless steel self-threading bolts: Use to cut threads into 5/16" holes. Drill 5/16" hole. Turn 3/8" x 1" self-threading bolt in hole to cut threads, then turn back out.

SAFETY INFORMATION

▲ DANGER: Mounting replacement tarp to a structurally weak or damaged roll tube can result in serious injury or death.

Before installing replacement tarp, inspect mounting surface of roll tube. Be aware several mounting holes in close proximity may compromise roll tube strength and integrity. Ensure mounting location on roll tube provides adequate tarp support.

- Disconnect power before servicing tarp system or electrical components.
- Always use caution when operating tarp system.
- Ensure people and objects are clear of tarp system before and during operation.
- Instruct everyone who will operate tarp system on the proper procedures.
- Never allow children to operate or play with tarp system.
- Do not operate tarp system with box hoisted in elevated position.
- Ensure tarp system is fully open or fully closed before operating vehicle at highway speeds.
- Only operate tarp system when tarp is completely visible.
- Always refer to OEM instructions before installing electrical components.
- Do not use arm as a step.
- Remove snow or debris from top of tarp system before operating.
- End caps must be free from commodity. Commodity should not be piled higher than end caps.
- Do not directly spray motor or connections with a pressure washer.
- Ensure tarp system is fully open before unloading or loading.

NOTE: Safety and operating procedure decals provided with this kit should be kept clean at all times and replaced if worn, damaged, painted over or unreadable.

1: INSTALLING AIR DAM

NOTE: For stainless steel hardware, see page 2 for bolting procedures.

A. Measure front width of box and air dam to ensure fit.

NOTE: If two people are present, clamping is optional.

B. Position top of air dam 2" above box and clamp or hold in place.

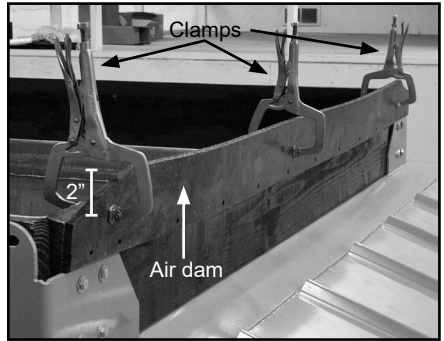

C. Using factory air dam holes as a guide, drill through air dam and box wall with 3/8" drill bit.

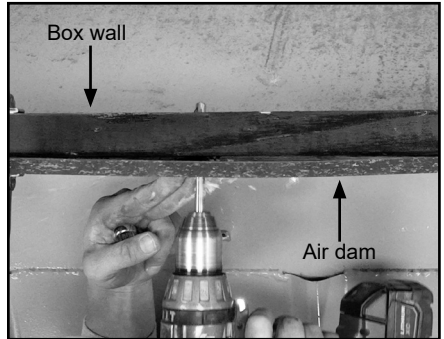

D. Insert carriage bolt through air dam and box wall.

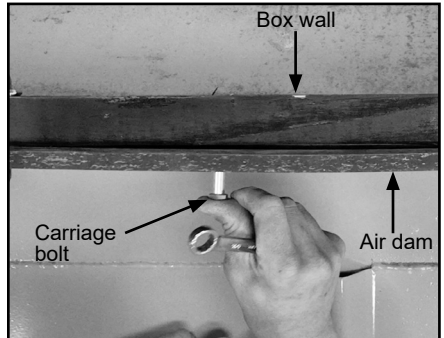

E. Place nylock flange nut on carriage bolt, finger tighten.

F. Repeat steps 1C-E for remaining bolt locations.

G. Fully tighten all hardware.

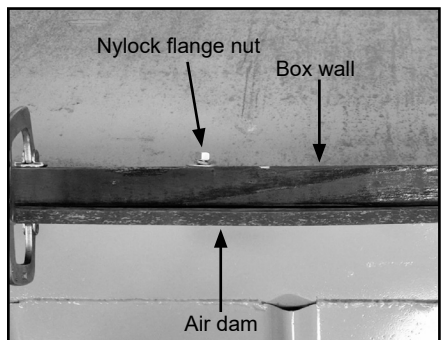

2: DETERMINING TARP STOP PLACEMENT

NOTE: Tarp stops secure stationary side of tarp to box.

- For normal roll applications, mount tarp stops on passenger side of box.
- For reverse roll applications, mount tarp stops on driver side of box.

A. Place front and rear tarp stops 8" from each end.

B. Divide space from front to rear tarp stop by number of tarp stops left plus one to determine position of remaining tarp stops.

*Example:

If - 2 tarp stops are left,
divide by 3 for 3 equal spaces

If - 4 tarp stops are left,
divide by 5 for 5 equal spaces

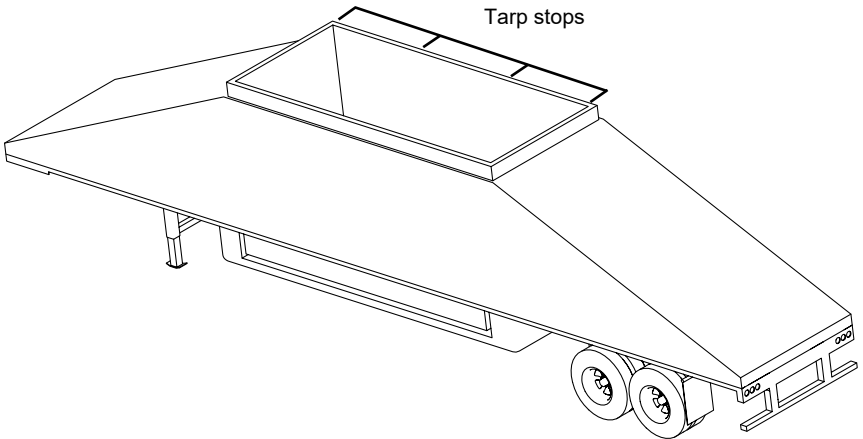

3: MOUNTING TARP STOPS

WITH WOOD EXTENSIONS

A. Measure 4" down from top of wood extension, place front and rear base brackets against wood extension and drill (4) 3/8" holes. Secure with (4) 3/8" x 2-1/2" bolts, flat washers and nuts.

B. Measure 4" down from top of wood extension, place remaining base brackets against wood extension and drill (2) 3/8" holes. Secure with (2) 3/8" x 2-1/2" bolts, flat washers and nuts.

C. Align lower hole in upright with lower hole in base bracket. Assemble with clevis pin and bow-tie pins. Leave tarp stop in open position for now.

D. Repeat Step 3C for remaining tarp stops.

NOTE: Install uprights with set screw at front and rear.

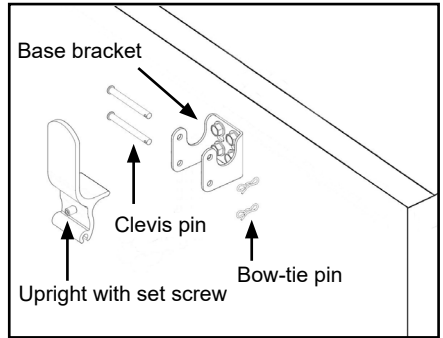
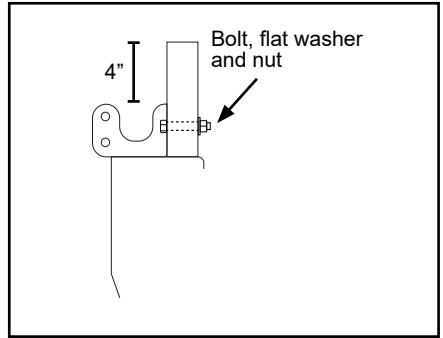

NOTE: If installing rubber uprights, drill 5/16" hole through rubber in line with stationary tube at front and rear. Secure with 3/8" x 1-1/4" self-threading bolt.

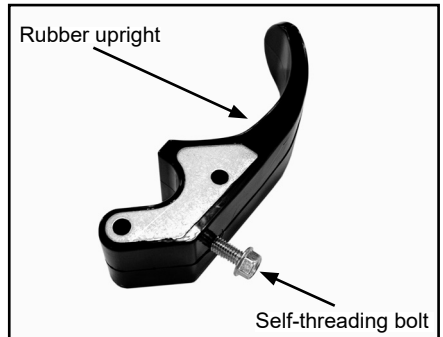

IMPORTANT: Round all trailer and extension edges or install tarp friendly edge guard (not furnished) to avoid tarp wear.

4: ATTACHING ROLL TUBE TO TARP

A. On a clean floor, lay tarp out flat with rope in large pocket facing down and exterior side facing up (raw edge of hems and pockets are down).

NOTE: Ensure holes in large pocket and roll tube are on same side of rope.

B. Align channel on roll tube with rope.

C. Slide black end of roll tube onto rope and into large pocket.

IMPORTANT: Ensure rope is fully engaged in rope channel on roll tube.

D. Align holes in tarp and roll tube, then insert drive rivet. Ensure it is fully seated and set with hammer.

TIP: Liner tool helps align tarp and roll tube holes to fully seat rivet.

E. On other end, pull tarp by hand to align holes in tarp and roll tube, then insert drive rivet. Ensure it is fully seated and set with hammer.

NOTE: Tarp is designed to be stretched to minimize wrinkling.

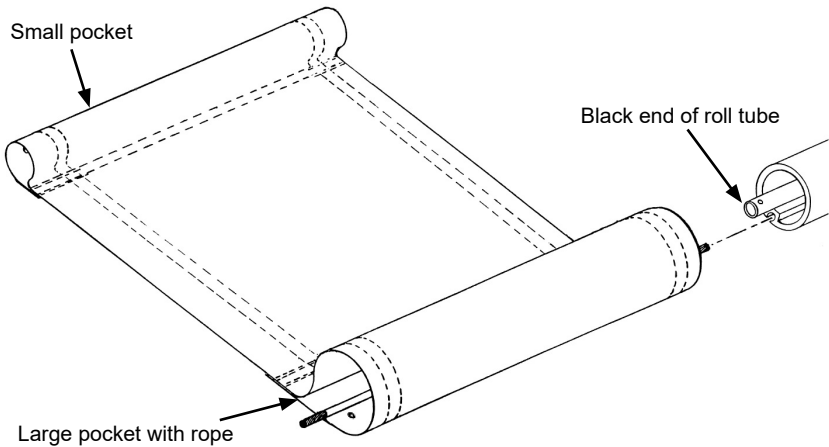

5: ATTACHING STATIONARY TUBE TO TARP

A. Tap end plug into each end of stationary tube.

B. Slide stationary tube into small pocket.

C. Align holes in tarp and stationary tube, then insert drive rivet. Ensure it is fully seated and set with hammer.

D. At other end, pull tarp by hand to align holes in tarp and stationary tube, then insert drive rivet. Ensure it is fully seated and set with hammer.

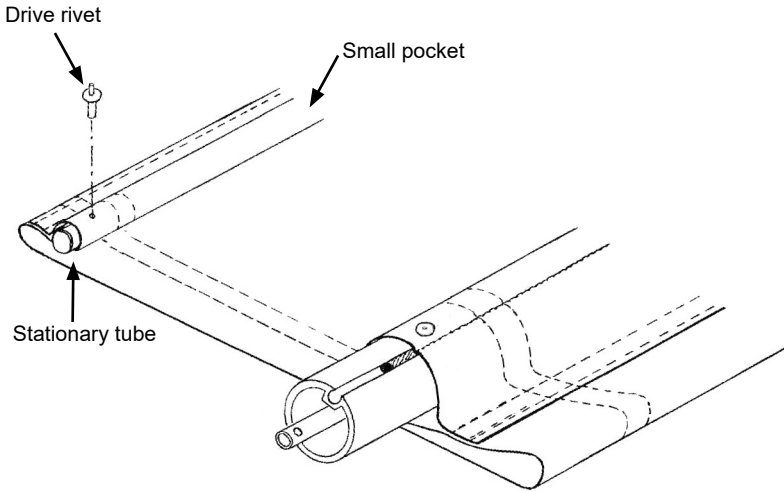

6: ATTACHING SPOOLS

NOTE: Spool marked R (right) use with red marked spring and cartridge.

IMPORTANT: Do not use grease or lubricant on spools or tube.

A. Slide spool onto end of roll tube according to (L) or (R) marking.

- For left spool (L), turn spool counterclockwise about 1" while pushing until spring engages in roll tube and spring tab engages hole in spool.
- For right spool (R), turn spool clockwise about 1" while pushing until spring engages in roll tube and spring tab engages hole in spool.

B. On non-drive side, slide short PVC spacer on cartridge and secure with clevis and cotter pins, then bend cotter pin tabs.

NOTE: Non-drive side is opposite of tarp motor or crank handle.

C. On drive side, slide long PVC spacer on cartridge, then insert clevis and cotter pins. Do not bend cotter pin tabs.

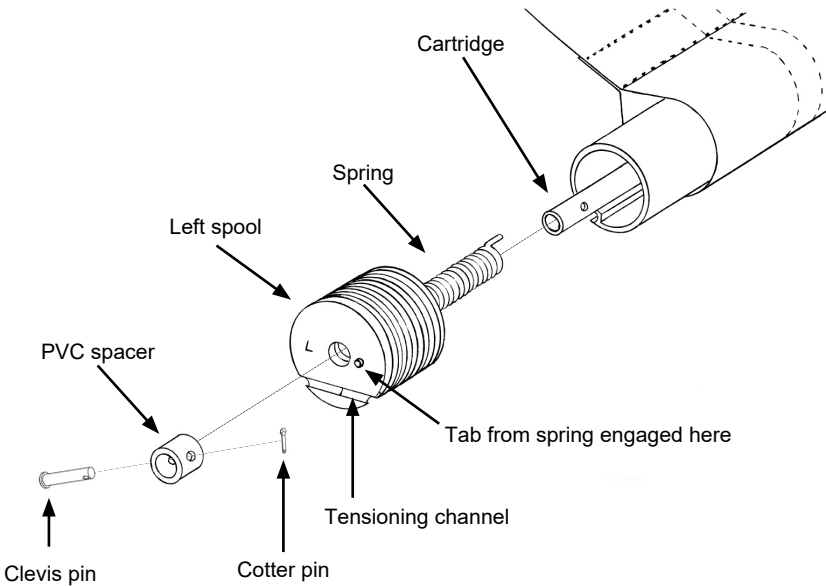

7: INSTALLING TARP ASSEMBLY

A. Roll tarp assembly by hand to open position, roll tube to stationary tube.

B. Place stationary tube into base brackets.

C. Center assembly from front to rear of box. Be careful not to let tarp roll off box.

- For normal roll applications, red end goes to the rear, black end to the front.
- For reverse roll applications, black end goes to the rear, red end to the front.

D. Swing upright up and secure with clevis and bow-tie pins.

E. Repeat Step 7D for all tarp stops.

F. Tighten fasteners at front and rear tarp stops.

IMPORTANT: Fasteners prevent tube and tarp from sliding.

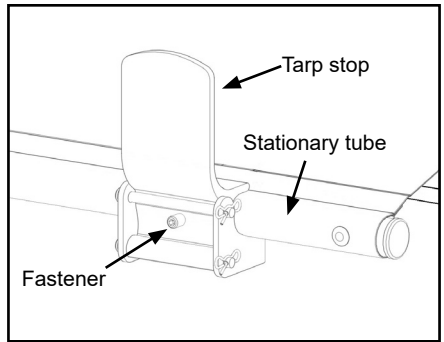
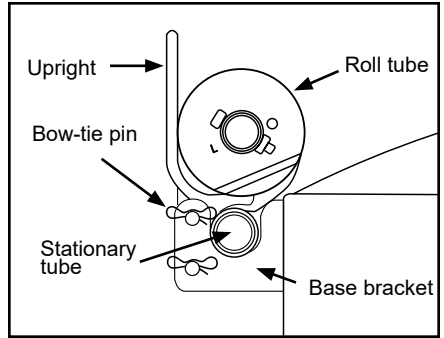

8: INSTALLING CABLES & RATCHETS

NOTE: For stainless steel hardware, see page 2 for bolting procedures.

- A. Unroll tarp by hand to other side of box and let tarp hang down. Ensure tarp is still centered from front to back of box and make adjustments as needed.
- B. Attach barrel end of cable to barrel groove on spool. Ensure cable follows grooves.
- C. Wrap cable around spool grooves up to last full wrap with cable next to box wall.

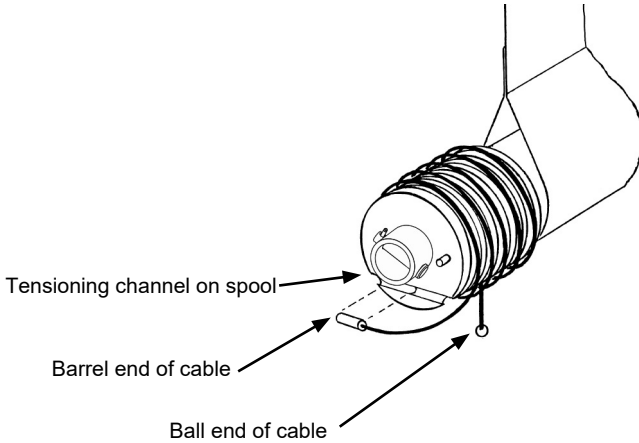

8: INSTALLING CABLES & RATCHETS (Continued)

D. Determine location for diverter. The cable diverter should be positioned 1 to 2 degrees away from tarp while allowing the cable to angle, maintain tension and attach to ratchet.

E. Mark, then drill location with 3/8" bit.

F. Install cable diverter with carriage bolt, flat washer and hex nut.

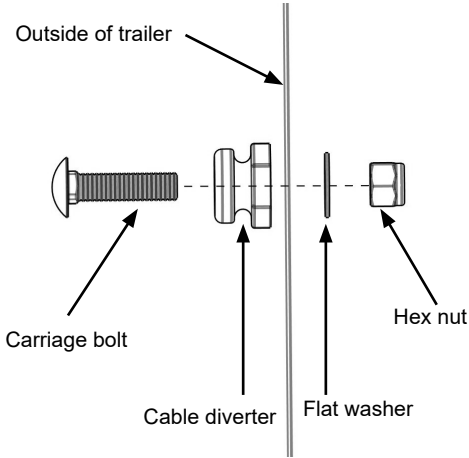

8: INSTALLING CABLES & RATCHETS (Continued)

G. Route cable around diverter, attach ball end of cable to ratchet to determine location for ratchet.

H. Pull down on ratchet while activating the release to extend ratchet to mark on strap, around 10-1/2" down. Mark (2) bolt locations on top of box.

I. Drill 5/16" holes at marked locations and secure with 3/8" x 1" self-threading bolts, when possible use nuts on inside of box. Ratchet must be securely mounted to top of box.

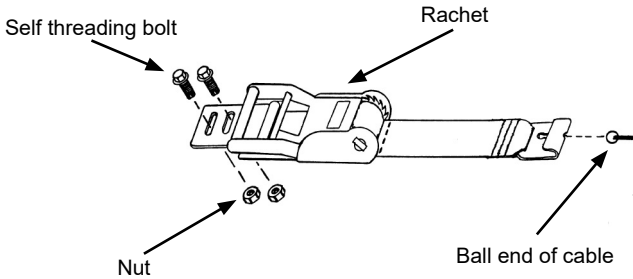

NOTE: Cable routing should appear as shown.

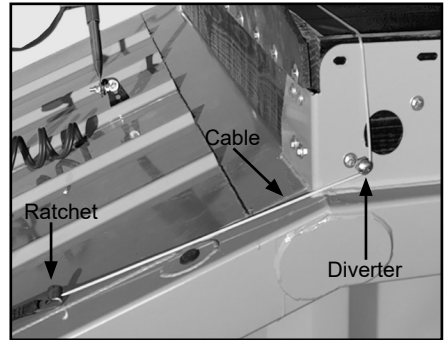

J. Repeat Step 8A-I to install cable and ratchet at opposite end of box.

K. Ensure cables follow grooves on spools when operating tarp.

L. Locate and clean a suitable location to apply ratchet decal.

9: CABLE TENSION

A. As tension is applied with ratchet, the spool will turn. Proper tension is achieved when the tension channel is level at bottom.

TIP: Tighten ratchet an additional two clicks past level. Open and close tarp system approximately 5 times to pull tarp snug. Install crank handle or motor prior to opening and closing tarp system.

IMPORTANT: Periodically check tension level and always keep ratchet handle in locked down position during use.

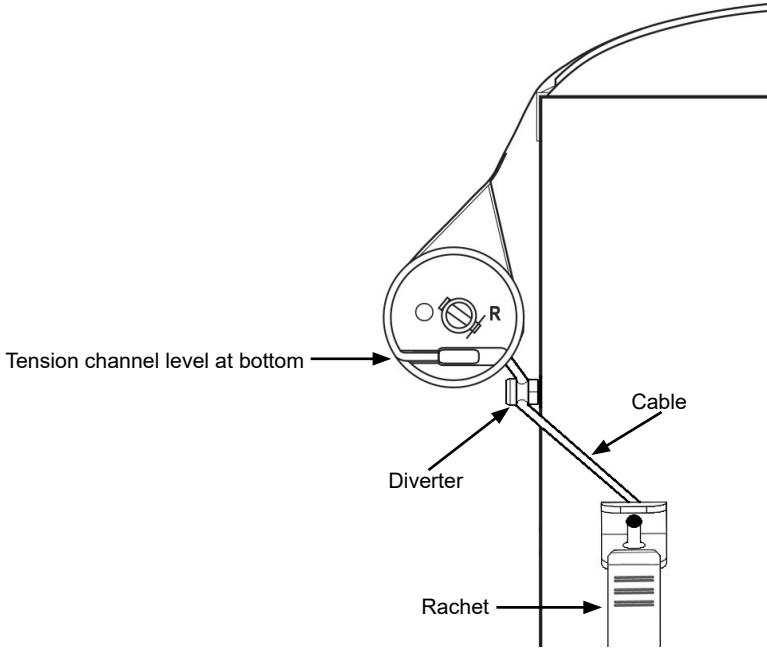

9: CABLE TENSION (Continued)

NOTE: After tensioning spool to horizontal position and tarp has been cycled, if cable has excessive slack, tighten ratchet to apply additional tension up to 25° and cycle again. Repeat as needed.

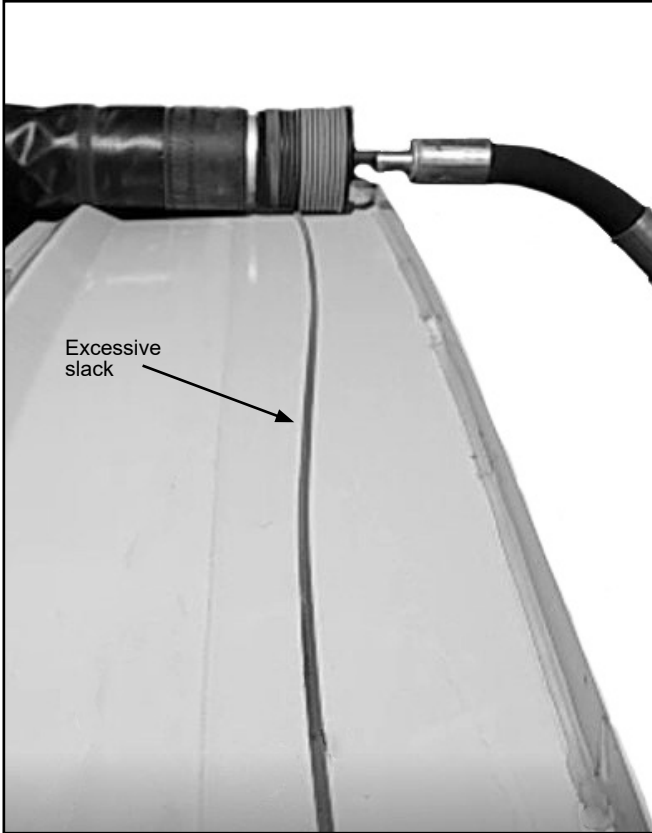

10: MOUNTING LOWER PIVOT ARM

NOTE: For manual installation proceed to Step 13.

NOTE: For stainless steel hardware, see page 2 for bolting procedures.

A. At front of trailer, align center point of mounting bracket with center line of box. Using mounting bracket as a guide drill 5/16" holes and secure with self-threading bolts.

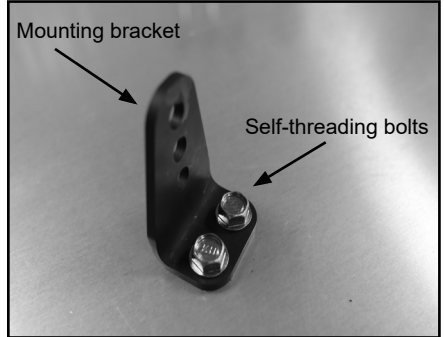

B. Place flat washer on hex bolt, insert through secondary bracket and mounting bracket and secure with flat washer and nut.

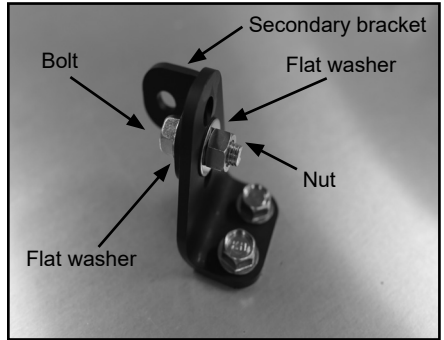

10: MOUNTING LOWER PIVOT ARM (Continued)

C. Place flat washer on hex bolt, insert through secondary bracket and secure with flat washer and nut.

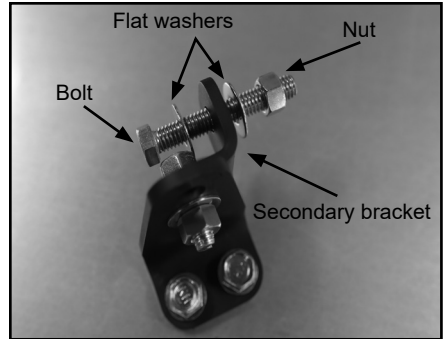

D. Thread nylock nut on hex bolt and place flat washer on bolt. Place lower pivot arm on hex bolt and secure with flat washer and nylock nut.

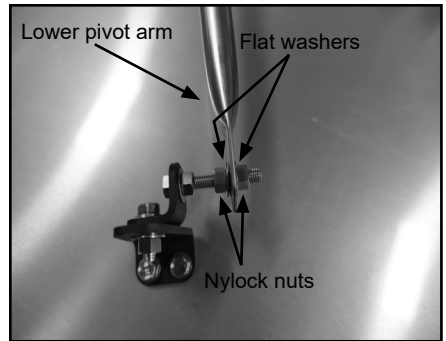

11: ATTACHING MOTOR

A. Secure motor to upper pivot arm mount using (3) 5/16" x 3/4" bolts with lock washers.

B. Slide upper pivot arm with motor over top of lower pivot arm.

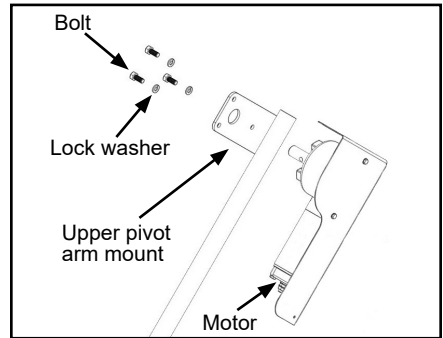

C. Lift motor and arm up to cartridge on roll tube then square motor with roll tube.

NOTE: If not installed square with roll tube and pivot mount, motor will bind and wobble during operation.

D. Mark PVC spacer and cartridge 5/16" from upper pivot arm mount.

IMPORTANT: Ensure path of motor arm is free of obstructions.

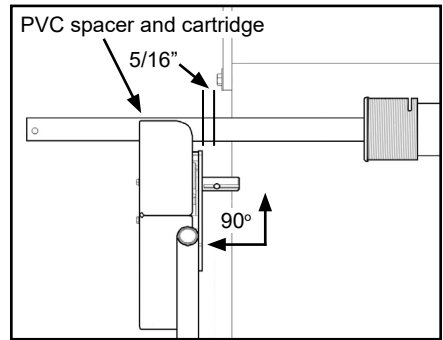

E. Cut cartridge and PVC spacer at marked location. Remove clevis and cotter pins, save for later.

F. Make mark on PVC spacer 1/2" in from end and drill pilot hole, then drill 5/16" hole through PVC spacer and cartridge.

NOTE: Ensure to drill squarely through both parts.

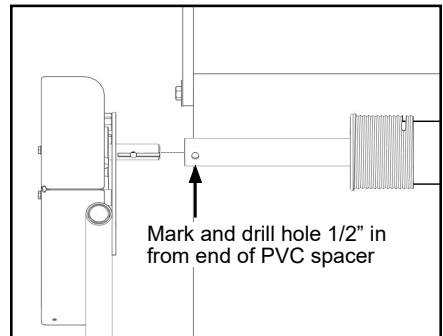

G. Insert drive shaft on motor into cartridge.

H. Turn roll tube by hand until holes align and secure with previously removed clevis and cotter pins. Bend cotter pin tabs.

TIP: Periodically grease motor extension.

NOTE: If lower pivot arm extends past top of motor in closed position, trim off excess. Then reinsert nylon plug into top of lower pivot arm.

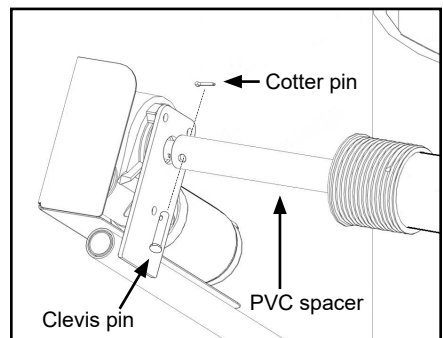

12: ELECTRICAL

- A. Locate and clean suitable locations to apply caution stickers.
- B. Refer to included instructions to complete wiring.

13: INSTALLING CRANK HANDLE ASSEMBLY

- A. Remove clevis and cotter pins securing PVC spacer at rear of box.
- B. Slide handle through PVC spacer and into cartridge protruding from spool.
- C. Align holes in handle, PVC spacer and cartridge then secure with clevis and cotter pins. Bend cotter pin tabs.

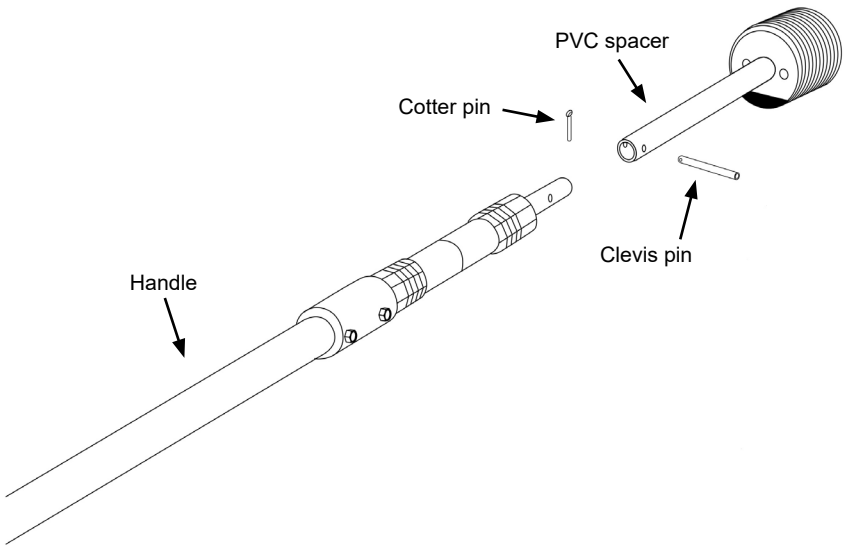

14: MOUNTING HANDLE HOLDER

NOTE: For stainless steel hardware, see page 2 for bolting procedures.

A. With tarp in closed position, snap handle holder onto crank handle and select best location on side or top rear corner. Mark hole.

B. Roll tarp to open position and select best location on adjacent side or top corner. Mark hole.

C. Drill 5/16" holes at marked locations and secure handle holders with 3/8" x 1" self-threading bolts with threadlock adhesive.

D. Locate and clean suitable positions to apply caution and important stickers.

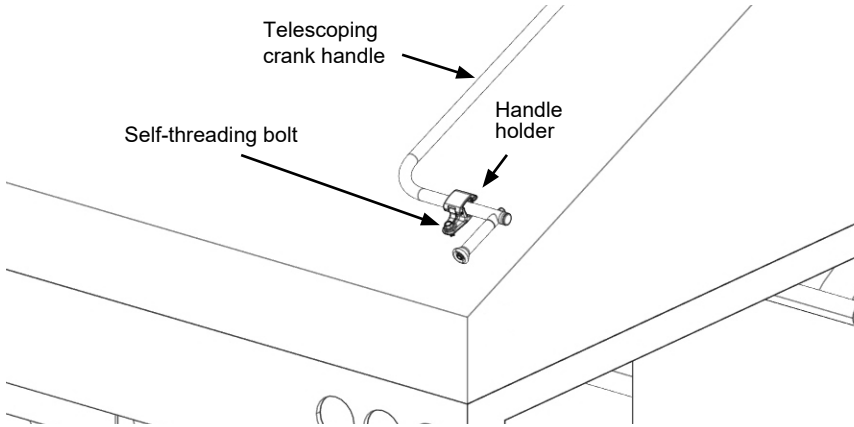

TROUBLESHOOTING

Cables do not stay in grooves on nylon spools when operating.

Tarp doesn't wind smooth. Binds on one end or both ends.

Cannot fully open tarp. (On boxes wider than 11' 6" it is normal for tarp to stop 6" to 8" from edge of box.)

Tarp sags in middle area.

Holes or tears in tarp.

Cable ratchets may need offset adjustment.

Check level of tension channels for proper tension.

Fasteners may be loose allowing tarp to "slip or walk." Recenter tarp between end caps. Tighten fasteners.

Spools may be binding on roll tube, clean and reinstall.

Cable tension may be too loose. Check level of tension channels for proper tension.

Tarp has been altered or improperly repaired.

Cable tension may be too loose. Check level of tension channels for proper tension.

Contact your local Agri-Cover dealer for replacement tarp or tarp repair kit.

When new tarp or parts are needed replace with original Agri-Cover parts.

OPERATION

TO CLOSE

- A. Use both hands to remove crank handle from holder. Extend crank handle to a comfortable operating position.
- B. Roll tarp to completely closed position.
- C. Push crank handle into holder and close.

TO OPEN

- A. Use both hands to remove crank handle from holder. Extend crank handle to a comfortable operating position.
- B. Roll tarp to completely open position.

NOTE: Completely open is when tarp roll touches tarp stops. Attempting to roll tarp past open position could cause damage to tarp stops, tubes and tarp.

- C. Push crank handle into holder and close.

INSPECTION AND MAINTENANCE

Periodic preventive maintenance should be practiced:

- Inspect tarp and hardware for abrasions or loosened bolts that may need adjustment. Adjust tension when needed. Tarp must be kept to a recommended tension setting equally on both ends, or excessive tarp wear may occur.
- Tarp should always operate as well as when first installed. Make all appropriate repairs or adjustments immediately before serious damage occurs.
- Check the tightness of mounting bolts and electrical connections, remove any dirt or corrosion that may have accumulated on the electrical connections.
- Always use genuine Agri-Cover, Inc. replacement parts, use serial number to easily order replacement tarp.

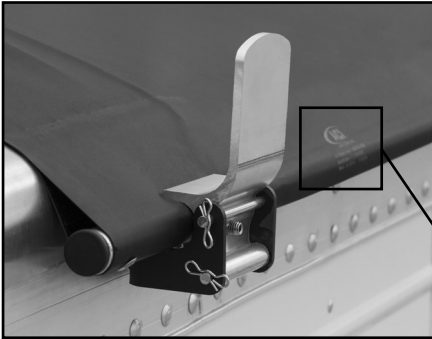

Serial number is located at rear of tarp on stationary tube side



MANUFACTURER'S LIMITED WARRANTY

Agri-Cover, Inc. extends the following Limited Warranty on its SRT-2® Spool Roll Tarp:

Agri-Cover, Inc. warrants its SRT-2® Spool Roll Tarp to be free from defects in material and workmanship under normal use for one (1) year from date of manufacture unless accompanied by proof of purchase. This Limited Warranty does not cover any failure due to abuse, misuse, alteration, neglect, improper assembly or installation, or improper maintenance.

ANY IMPLIED WARRANTY APPLICABLE TO THE SRT-2® SPOOL ROLL TARP IS LIMITED IN DURATION TO ONE YEAR FROM THE DATE OF MANUFACTURE UNLESS ACCOMPANIED BY PROOF OF PURCHASE. Agri-Cover Inc.'s sole obligation under this Limited Warranty or any implied warranty is limited to the repair or replacement at its option, of defective parts only. No labor or service allowance is given or implied. IN NO EVENT SHALL AGRI-COVER, INC. BE LIABLE FOR INCIDENTAL, CONSEQUENTIAL, OR SPECIAL DAMAGES. EXPRESSLY DISCLAIMS ANY AND ALL IMPLIED WARRANTIES OF MERCHANTABILITY, AND THERE ARE NO WARRANTIES WHICH EXTEND BEYOND THE LIMITED WARRANTY DESCRIPTION CONTAINED HEREIN.

For warranty, have serial number ready and fill out the warranty claim form at agricover.com/warrantyclaim or call Customer Service Department at (800) 233-4655 to determine if only a replacement part is needed or if the tarp needs to be returned for inspection and repair. Goods to be returned must have a pre-authorized RA # (Return Authorization Number) – obtained by calling the number above. Mark the number on the package and ship it freight prepaid to address below. Agri-Cover will pay freight to return goods to sender.

This Limited Warranty gives you specific legal rights and you may have other rights, which vary, from state to state.

For replacement parts shop at agricoverparts.com or call Customer Service at (800) 233-4655.



Agri-Cover, Inc.
Customer Service Dept
3000 Hwy 281 SE
Jamestown, ND 58401
Phone: (800) 233-4655

Hours: 8:00 am - 5:00 pm CST Monday through Friday, except Holidays