



INSTALLATION INSTRUCTIONS

Thank you for purchasing SNOWSPORT® 180 Utility Plow. Agri-Cover, Inc. proudly manufactured this snowplow using superior quality materials and workmanship. With proper care, your snowplow will provide years of service and enjoyment.

NOTICE TO INSTALLER: Even if familiar with product, read instructions prior to installation as improvements may be made without notice. Always handle components with care. If you have questions or problems, have serial number ready and call customer service. When done, these instructions must be given to the consumer.

NOTICE TO CONSUMER: Before using this product, read safety and operation sections. Save these instructions for future reference.

FOR YOUR RECORDS

DATE PURCHASED: _____

WHERE PURCHASED: _____

SERIAL NUMBER: _____

(Located on back of snowplow blade)



Questions? 800-689-6612
agricover.com

PREPARATION

Unpack snowplow components. For additional installation assistance, go to mysnowsport.com for install and operation videos.

COMPONENTS

- (1) Push frame
- (1) Straight interceptor kit
- (1) Rubber blade
- (1) Aluminum blade
- (2) Skid brackets
- (2) Slide hinges
- (2) Blade markers
- (1) Quick pin set
- (1) Set collar
- (4) 1/4" x 1-1/2" Carriage bolts
- (4) 3/8" x 3/4" Hex bolts
- (4) 3/8" Flat washers
- (4) 3/8" Square nuts
- (4) 1/4" Flat washers
- (4) 1/4" Lock washers
- (4) 1/4" Hex nuts
- (6) 3/8" x 1" Hex bolts with washers
- (2) 1/2" x 4" Hex bolts
- (2) 1/2" Hex nuts
- (1) 5/8" x 3" Receiver pin
- (1) Hair pin
- (4) 1/2" Flat washers

TOOLS NEEDED

- Drill with 5/16" bit
- 9/16" Socket with ratchet or impact driver/wrench
- (2) 3/4" Box wrenches
- 3/16" Hex key
- Ft-lbs Torque wrench with extension socket
- Protective eyewear
- #3 Phillips driver bit

NOTE: Prior to plow assembly, park vehicle on level grade. Measure clearance under existing 2" rear receiver, for best results receiver should be 8-14" above grade.

▲ CAUTION: Over torquing hardware may damage components.

SNOWPLOWING TIPS

The SNOWSPORT® 180 Utility Plow is designed to make moving snow convenient and easy by following simple tips.

- Check local regulations before plowing snow.
- Always keep current with snowfall. It's easier to plow fresh snow.
- From the start of the season, push snow far enough out to allow for future snowfall.
- Wet snow can compact and freeze which requires chipping to break it loose before attempting to move it.
- If snow is deep and/or compacted you may need to go over it two or three times.
- If blade is kept in warm storage, set blade outside and allow to cool, this prevents snow from freezing to blade when plowing.
- When starting a pass, accelerate slowly, allowing for tire traction and blade to accumulate snow.
- When coming to the end of a pass, reduce speed and apply brakes as needed.
- When pushing snow up to piles, drive straight, not at an angle.
- When pushing new snow to stack up against hardened piles, start a new pile first and then push it up on to hard pile.

SAFETY INFORMATION

Review the following safety information before moving snow:

- Always follow vehicle manufacturer recommendations for snowplowing.
- Always exercise safety, courtesy and common sense.
- Always know the terrain before plowing.
- Always wear your seat belt.
- Always look where you are going when backing up, don't rely on rear or side view mirrors.
- Always plow snow during low-traffic hours.
- Always be cautious of pedestrians and vehicles.
- Always be aware of engine temperature, avoid overheating.
- Always transport blade in retainer groove secured by quick pins.
- Always use lowest transmission gear, on 4WD select low range if equipped.
- Never overload your equipment, push only enough snow with each pass to get the job done.
- Never ride the clutch (on vehicles with manual transmission).
- Never plow snow with your head out of the window, an unexpected sudden stop could result in personal injury.
- Never exceed 65 MPH when transporting plow.
- Never exceed 5 MPH when plowing.
- Never pile snow where it obstructs visibility of traffic.
- Never pile snow near handicapped or parking areas.
- Never pile snow on someone else's property, streets, sidewalks, mail boxes, water drains, electrical boxes or by fire hydrants.
- Periodically inspect the condition of hardware. Check for loose bolts and parts, tighten if needed.

PARTS DIAGRAM

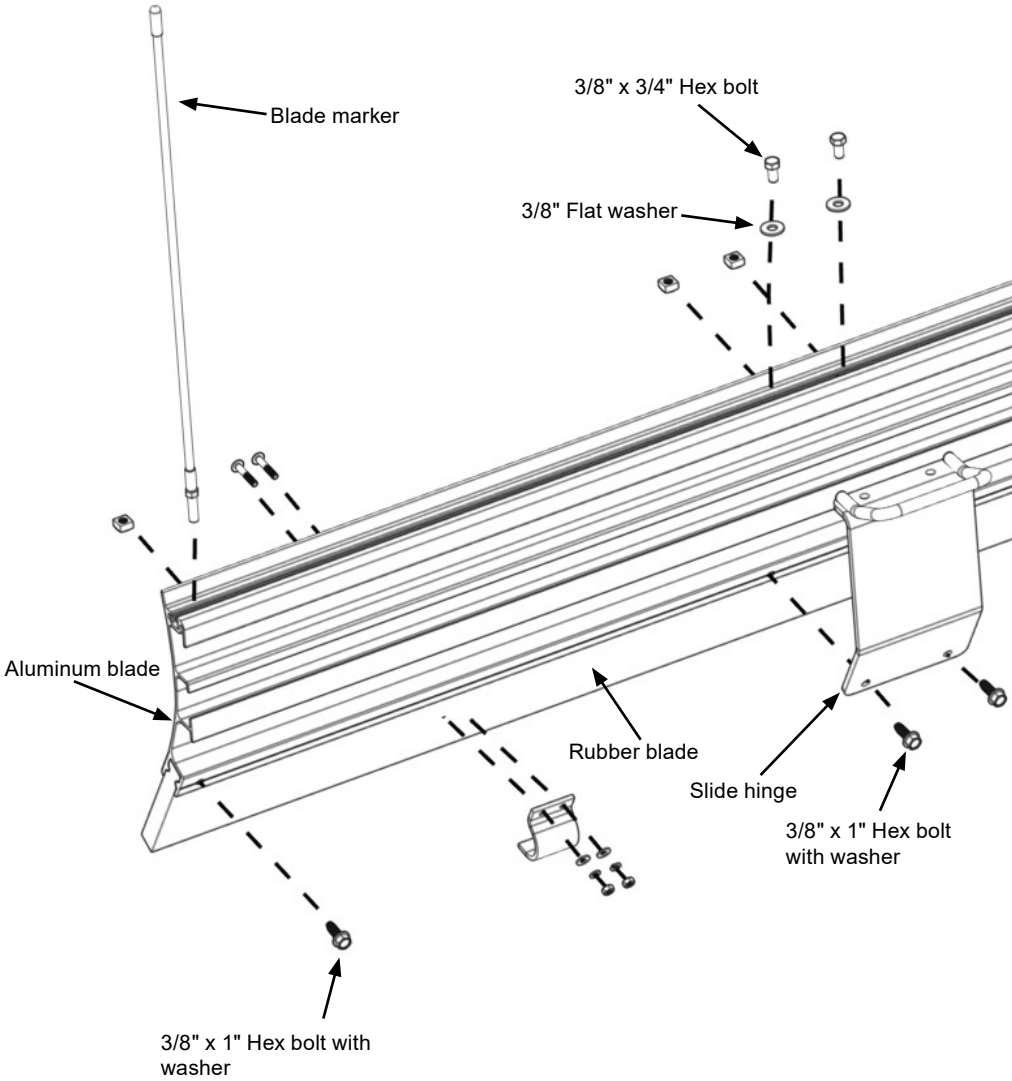

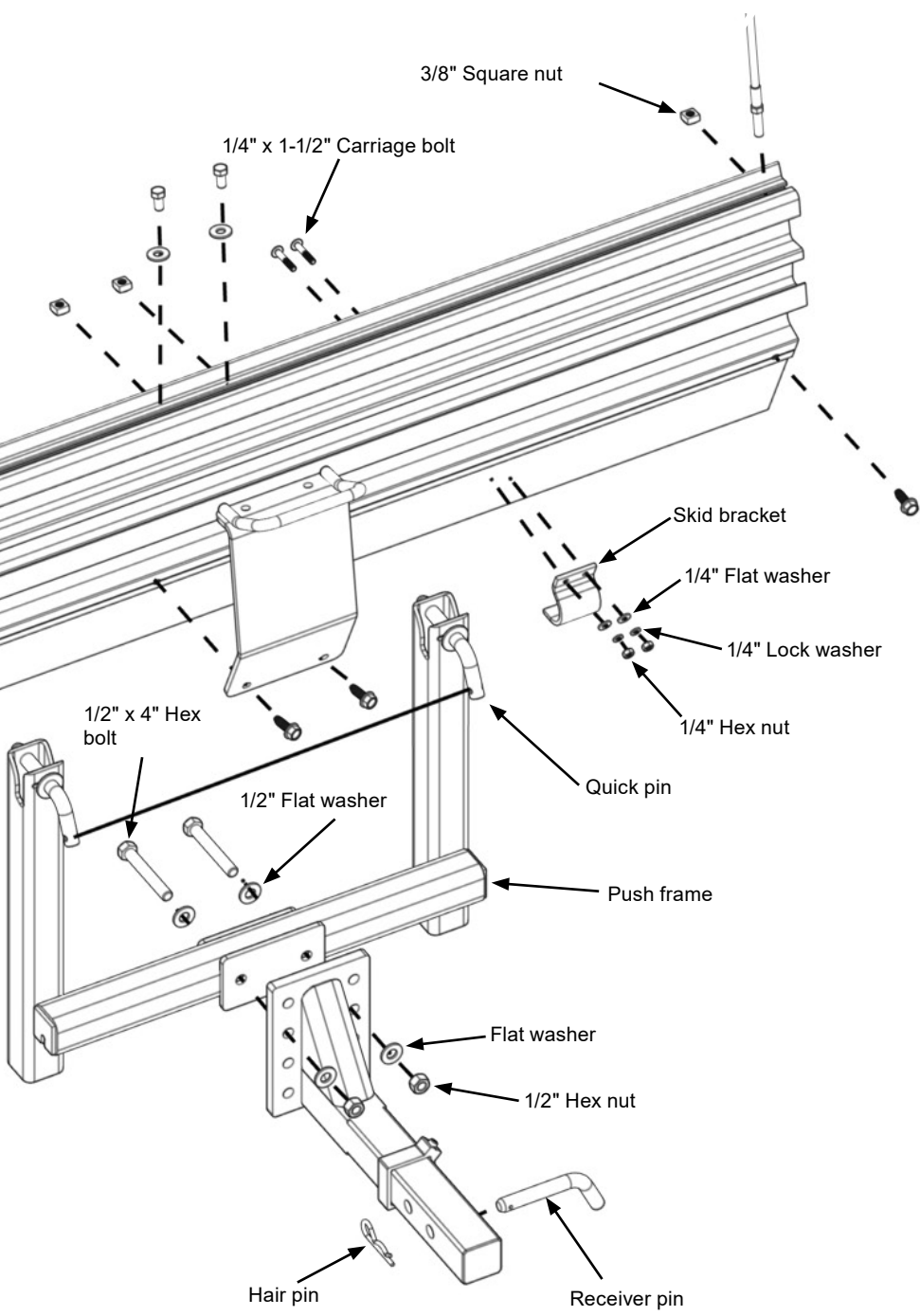

1: INSTALLING PUSH FRAME

NOTE: We recommend performing this step with two people. One person holds the push frame to the interceptor while another performs the installation.

A. Insert interceptor into receiver with push frame mounting bracket facing up. Secure interceptor with receiver pin.

B. Hold push frame against interceptor. Select 2 bolt hole pattern that positions push frame 6-8" above grade.

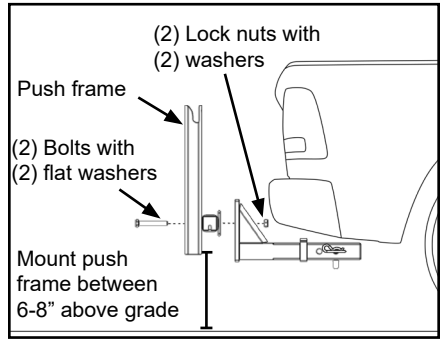

NOTE: In some cases, clearance under receiver may be less than 6". If so, plow will still operate properly, but ground clearance will be limited. Use care on uneven surfaces.

NOTE: If lowest bolt pattern is too high, remove interceptor and reinsert with push frame mounting bracket facing down.

Bolt push frame to interceptor with (2) 1/2" x 4" bolts, flat washers and lock nuts.

C. Verify 2 bolt hole pattern provides correct push frame clearance, 6-8" above grade then tighten bolts.

D. Torque 2 nuts to 90 ft-lbs.

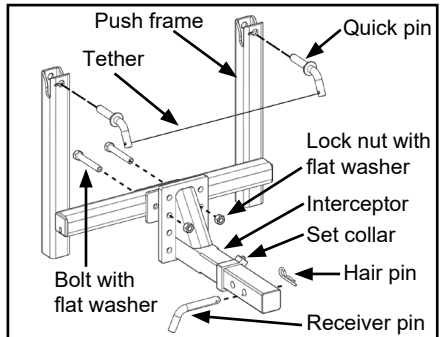

E. Push set collar tight against receiver, hold and tighten set screw with 3/16" hex wrench.

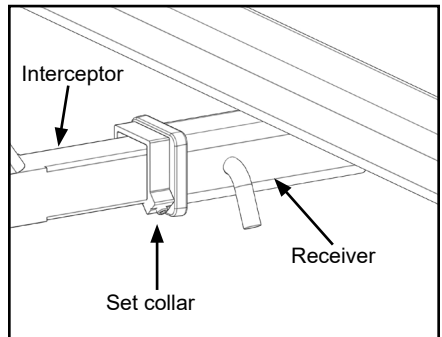

2: ASSEMBLING SNOWPLOW

A. Each end of the rubber cutting edge has two factory marks (to match with holes in skid bracket). Drill them out with 5/16" bit.

B. Mount skid bracket as shown to rubber cutting edge. Tighten bolts until head sinks flush with rubber surface. Repeat at other end.

NOTE: When mounted, skid bracket should align flush with or slightly above bottom of rubber.

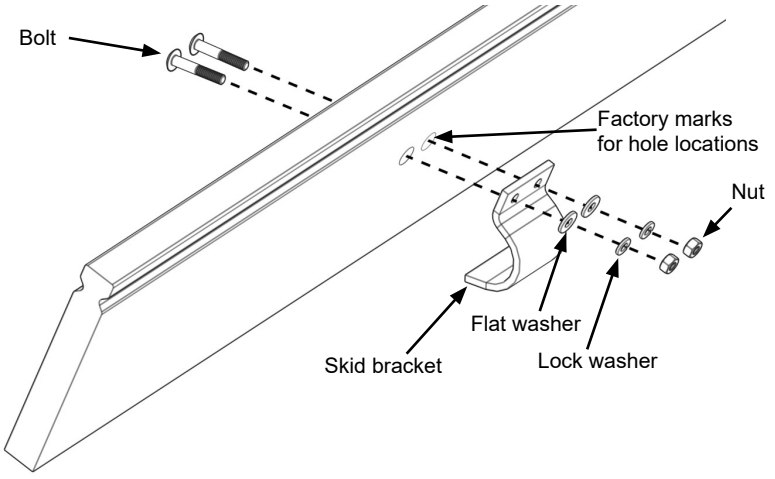

2: ASSEMBLING SNOWPLOW (Continued)

NOTE: Rubber blade should be room temperature before assembling.

C. With brackets facing back of blade, align rubber groove with blade mounting channel.

D. Slide rubber into channel in bottom of blade and center.

TIP: Apply soapy water solution to top of rubber blade and aluminum blade mounting channel for easier assembly.

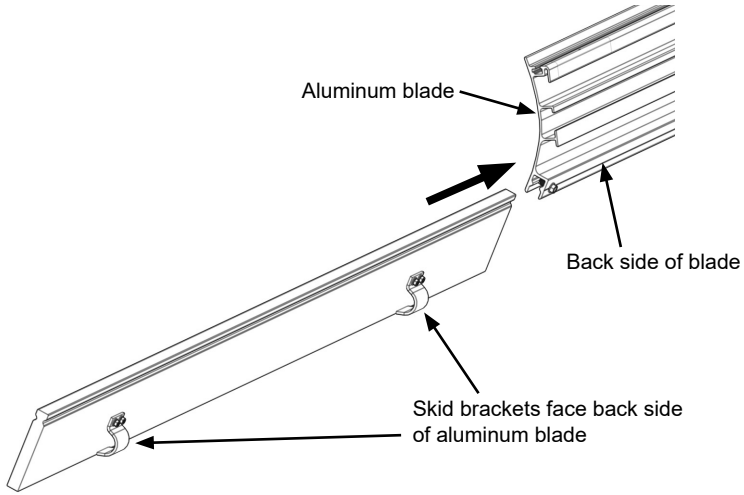

E. Locate factory marks on back of blade. Place slide hinge on blade as shown and align both lower holes with marks on blade.

TIP: When mounted, slide hinges should measure about 14-1/2" apart.

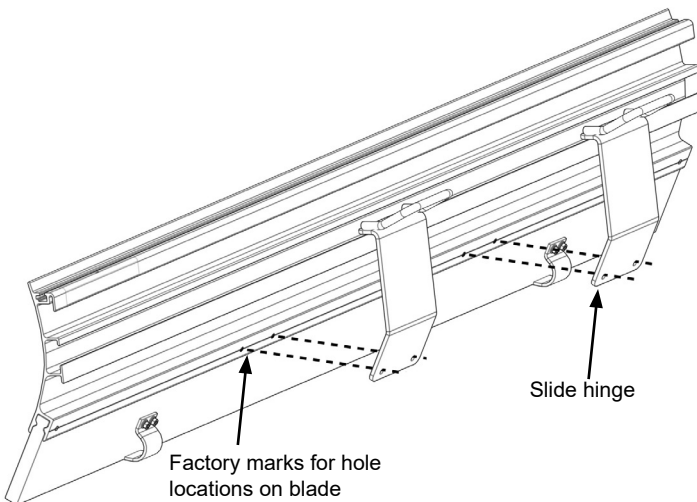

2: ASSEMBLING SNOWPLOW (Continued)

F. Insert (2) square nuts with flat side facing up in top channel of blade end and align with slide hinge top holes.

G. Insert $3/8"$ x $3/4"$ bolts with $3/4"$ washers through holes in slide hinge and thread into nuts inside channel.

H. Ensure both lower holes in slide hinge are still aligned with factory marks on blade, then tighten (2) top bolts.

I. Repeat Steps 2E-2H for opposite end.

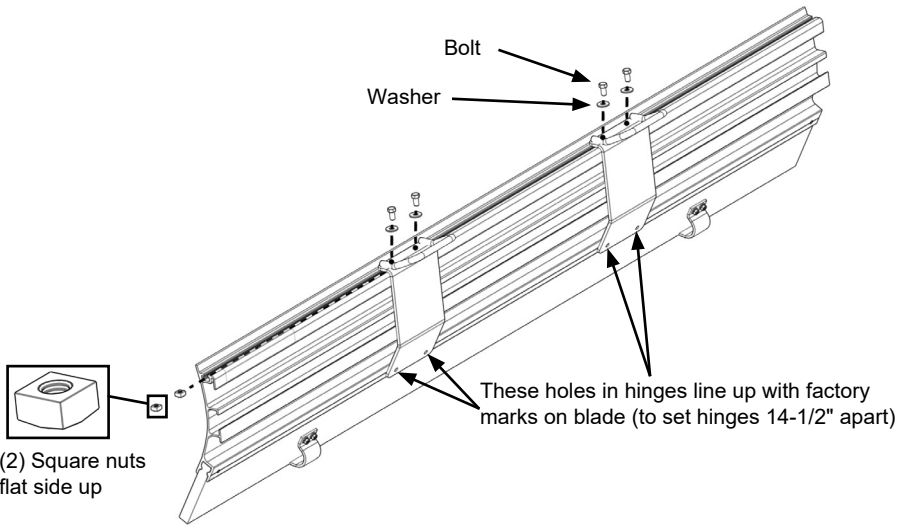

J. With rubber blade centered, use both lower holes in each slide hinge as guide to drill $5/16"$ holes through first layer of aluminum and partially into rubber. Then turn $3/8"$ x $1"$ self-threading bolt into each hole and tighten to secure each hinge.

K. At factory mark near each end of blade, drill $5/16"$ hole through first layer of aluminum and partially into rubber. Turn $3/8"$ x $1"$ self-threading bolt into hole and tighten.

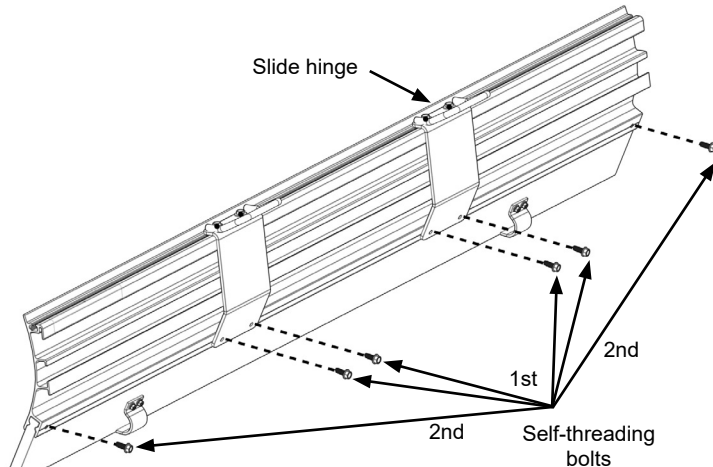

2: ASSEMBLING SNOWPLOW (Continued)

L. Hang 1 end of blade assembly into closest retainer groove on push frame. Repeat for opposite end of blade assembly.

M. Insert 1 quick pin in hole, rotate pin just enough to allow through second hole and then rotate back to its secure position. Repeat for remaining quick pin.

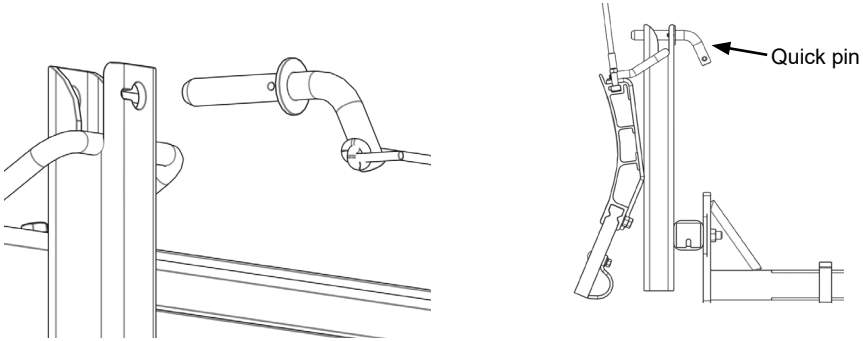

N. Turn hex jam nut (flange facing down) onto threaded base of blade marker.

O. Insert square nut flat side up into top channel of blade.

P. Align blade marker with edge of blade, turn base fully into square nut and tighten jam nut.

Q. Repeat for blade marker at other end.

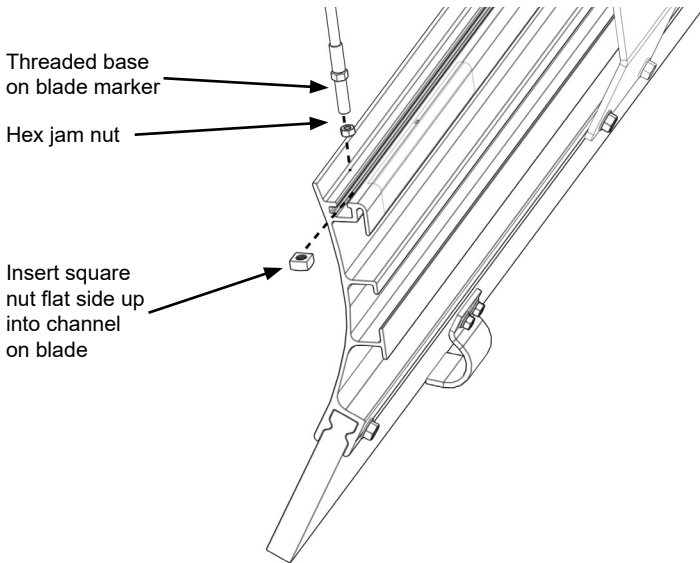

OPERATING INSTRUCTIONS

TO LOWER FOR PUSHING SNOW

Step behind and remove quick pin. Lift 1 side of blade out of retainer groove until slide hinge fits over the push frame bar, then lower blade to ground. Secure with quick pin. Repeat for opposite side of blade.

TO PUSH SNOW

Drive backward slowly, blade will engage for pushing. When push is finished, driving forward disengages the blade until you are realigned for next push. Repeat this procedure until job is finished.

TO STORE BLADE FOR TRANSPORTING

Step behind and remove quick pin. Hang 1 end of blade assembly into retainer groove on push frame. Secure with quick pin. Repeat for opposite side of blade.

TO STORE BLADE DURING OFF SEASON

For maximum blade life, periodically retighten bolts and protect blade from sun by storing inside or covering.

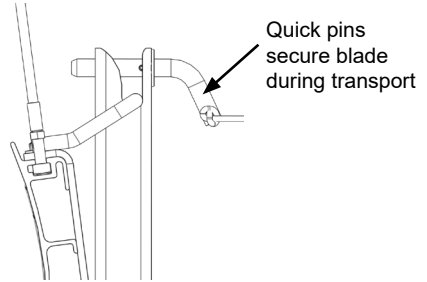
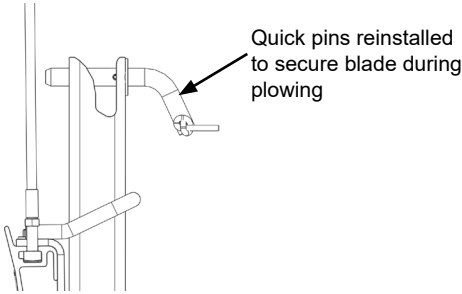

MANUFACTURER'S LIMITED WARRANTY

Agri-Cover, Inc. extends the following Limited Warranty on its SNOWSPORT® 180 Utility Plow:

Agri-Cover, Inc. warrants its SNOWSPORT® 180 Utility Plow to be free from defects in material and workmanship under normal use for one (1) year from date of manufacture unless accompanied by proof of purchase and separately warrants only the rubber blade portion of the SNOWSPORT® 180 Utility Plow to be free from defects in material and workmanship under normal use for three (3) years from date of manufacture unless accompanied by proof of purchase. This Limited Warranty does not cover any failure due to abuse, misuse, alteration, neglect, improper assembly or installation, or improper maintenance.

Agri-Cover's sole obligation under this Limited Warranty or any implied warranty is limited to the repair or replacement at its option, of defective parts only. No labor or service allowance is given or implied. IN NO EVENT SHALL AGRI-COVER, INC. BE LIABLE FOR INCIDENTAL, CONSEQUENTIAL, OR SPECIAL DAMAGES. AGRI-COVER, INC. EXPRESSLY DISCLAIMS ANY AND ALL IMPLIED WARRANTIES OF MERCHANTABILITY, AND THERE ARE NO WARRANTIES WHICH EXTEND BEYOND THE LIMITED WARRANTY DESCRIPTION CONTAINED HEREIN.

For warranty, have serial number ready and fill out the warranty claim form at agricover.com/warrantyclaim or call Customer Service Department at 800-689-6612 to determine if only a replacement part is needed or if the product needs to be returned for inspection and repair. Goods to be returned must have a pre-authorized RA # (Return Authorization Number) – obtained by calling the number above. Mark the number on the package and ship it freight prepaid to address below. Agri-Cover will pay freight to return goods to sender.

This Limited Warranty gives you specific legal rights and you may have other rights, which vary, from state to state.

For replacement parts shop at snowsportparts.com or call Customer Service at 800-689-6612.



Agri-Cover, Inc.
Customer Service Dept
3000 Hwy 281 SE
Jamestown, ND 58401
Phone: 800-689-6612

Hours: 8:00 am - 5:00 pm CST Monday through Friday, except Holidays