



Safety glasses should be worn at all times while installing this product.

YEARS: 2013

MAKE: RAM

MODEL: 3500

STYLE: TRUCK

WARNING: NEVER EXCEED YOUR VEHICLE MANUFACTURER'S RECOMMENDED TOWING CAPACITY

WEIGHT CARRYING:
 TRAILER WEIGHT: 5,000 LBS.
 TONGUE WEIGHT: 500 LBS.

**GROSS LOAD CAPACITY WHEN USED AS A STRAIGHT LINE PULL:
 9,000 LBS MAX.**

PRO INSTALL TIME: 30 MIN.
NOVICE INSTALL TIME: 60 MIN.

IF YOU ARE HESITANT TO UNDERTAKE THIS TASK ON YOUR OWN, CONTACT AN AUTHORIZED CURT INSTALLER FOR ADDITIONAL ASSISTANCE.



INSTALLATION REQUIRES:

 RATCHET	 18mm 15/16" SOCKET	 ROTARY TOOL
 CUT-OFF WHEEL	 SAFETY GLASSES	 MARKER
 TAPE MEASURE	 TORQUE WRENCH	 BOXED END WRENCH 15/16"

INSTALLATION TIPS:

- BEFORE YOU BEGIN INSTALLATION, READ ALL INSTRUCTIONS THOROUGHLY.
- TO EASE INSTALLATION, 2 PEOPLE MAY BE REQUIRED.
- USING PROPER TOOLS WILL GREATLY IMPROVE THE QUALITY OF THE INSTALL AND REDUCE THE TIME REQUIRED.
- NEED HELP OR HAVE SOME QUESTIONS? CALL TECHNICAL SUPPORT AT 800.798.0813

LEVEL OF DIFFICULTY: MODERATE

EASY	MODERATE	CHALLENGING
	NO DRILLING REQUIRED	
	AIR DAM TRIMMING REQUIRED	

VEHICLE PHOTO:

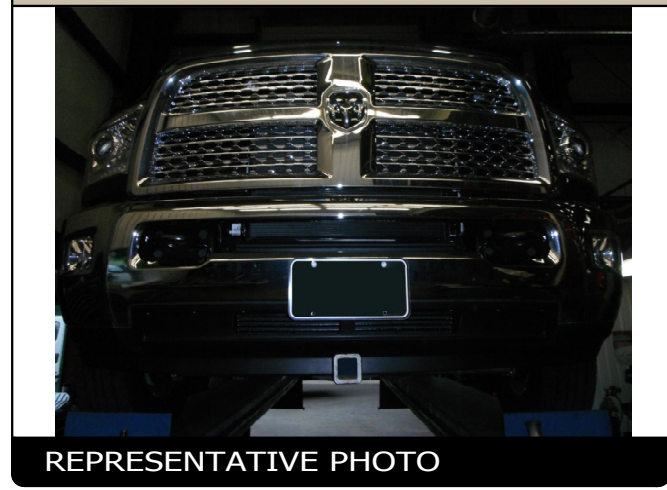

HITCH ILLUSTRATION:

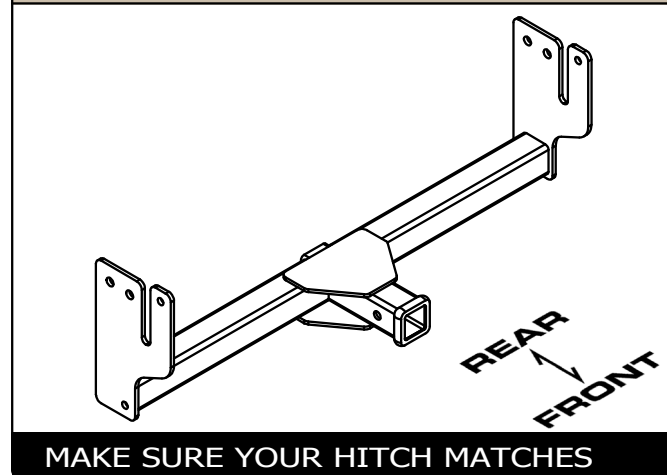

PERIODICALLY CHECK THIS RECEIVER HITCH TO ENSURE ALL FASTENERS ARE TIGHT AND ALL STRUCTURAL COMPONENTS ARE SOUND

CURT Manufacturing LLC. warrants this product to be free of defects in material and/or workmanship at the time of retail purchase by the original purchaser. If the product is found to be defective, Curt Manufacturing LLC. may repair or replace the product at their option, when the product is returned, prepaid, with proof of purchase. Alteration to, misuse of, or improper installation of this product voids the warranty. Curt Manufacturing LLC.'s liability is limited to repair or replacement of products found to be defective, and specifically excludes liability for incidental or consequential loss or damage.

For more information log onto www.curtmfg.com, & for helpful towing tips log onto www.hitchinfo.com

INSTALLATION WALKTHROUGH:

Parts List			
ITEM	QTY	PART NUMBER	DESCRIPTION
1	4	5_8 - 11 x 4 HEX	HEX BOLT
2	4	5_8 LOCK WASHER	LOCK WASHER
3	4	5/8"	WASHER WIDE
4	4	5/8-11	HEX FLANGE NUT
5	2	CM-SP42	.250 x 2.00 x 2.00" ROUND HOLE SPACER
6	2	31067-SP	SPACER PLATE .500" A-36 H.R. (1020)

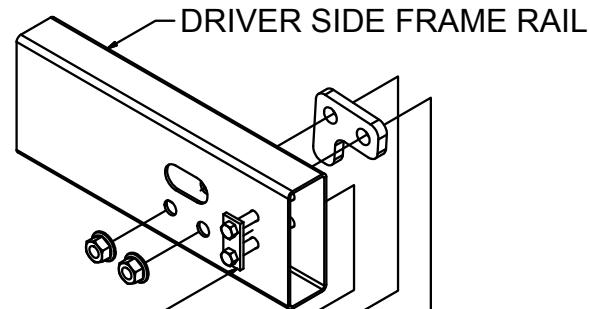

EXISTING HARDWARE

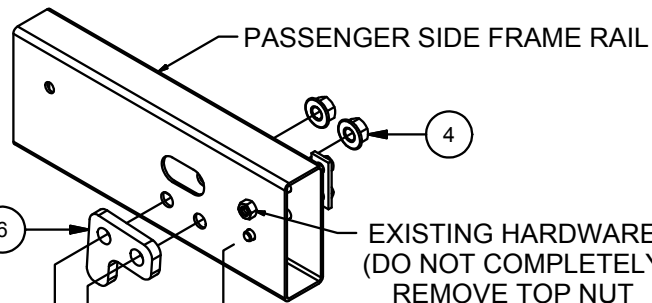

EXISTING HARDWARE
(DO NOT COMPLETELY REMOVE TOP NUT ON EITHER SIDE)

REAR
↑
FRONT

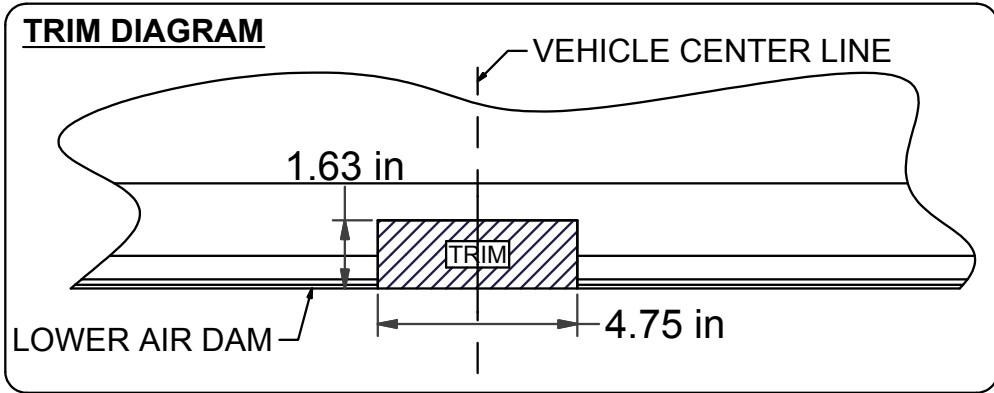
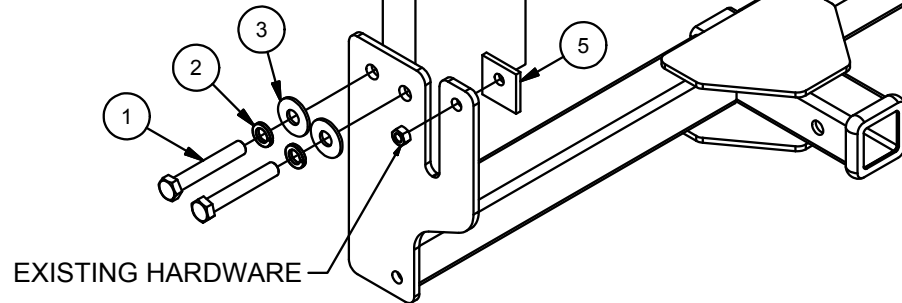

INSTALLATION WALKTHROUGH:

1. Trim lower air dam as needed for hitch, see trim diagram on page 2 for approximate trim location.



2. Remove two lower existing nuts from behind the bumper (one on each side), as shown on page 2. These lower two bolts are used to mount the hitch.

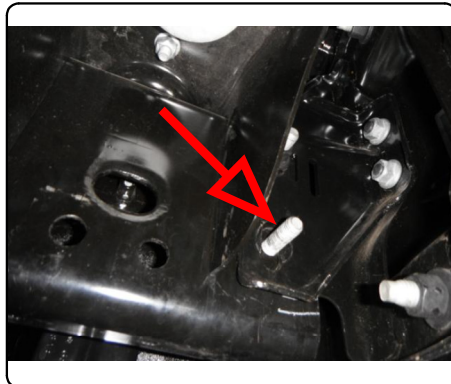

3. Loosen the top nut on each side until only a couple threads are engaged. The top nut will prevent the bolts from being pushed completely through. Push both sets of bolts towards the center of the vehicle.



NOTE:

Loosening these bolts will cause the bumper to shift down slightly. Pushing up on the bumper may take pressure off the bolts making them easier to move. If needed, use a soft mallet to tap the bolts in. The passenger side bolts may not go in as far in as the driver side bolts. **Complete removal of all four bolts will cause the bumper to fall.**

INSTALLATION WALKTHROUGH:

4. Place one CM-SP42 spacer (5) onto the exposed bolt on each side.

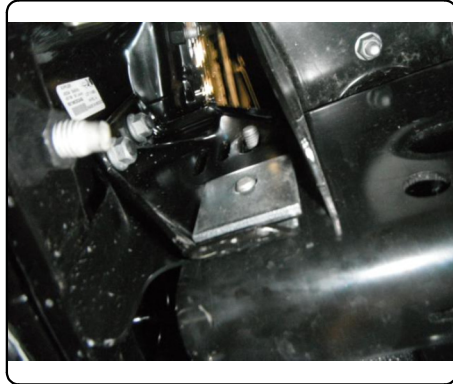
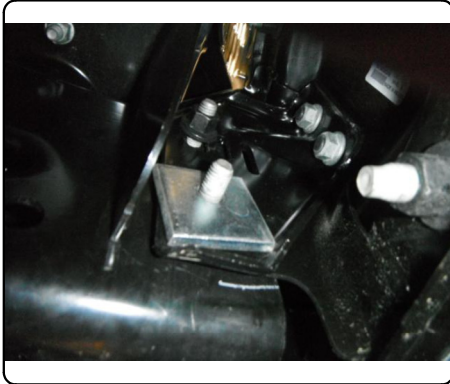

5. Raise the hitch into position by first raising the passenger side of the hitch and inserting the bolts back into position through the forward most hole in the hitch side plate. Rotate the driver side of the hitch up into position and push the bolts back towards the outside of the vehicle.

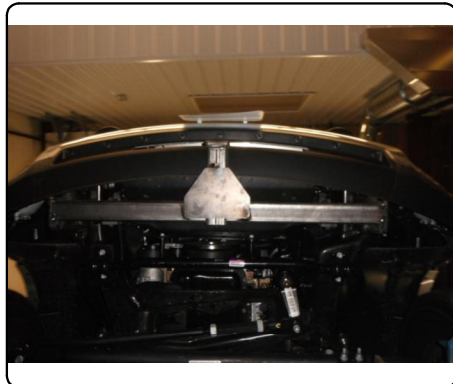

6. Insert spacer plate (6) between the frame and hitch side plate. Insert two 5/8" x 4" hex bolts (1) with a lock washer (2) and washer (3) on each. Insert in through the side plate / spacer and out the frame, as shown on page 2. Attach using two 5/8" hex flange nuts (4) and repeat on the other side.

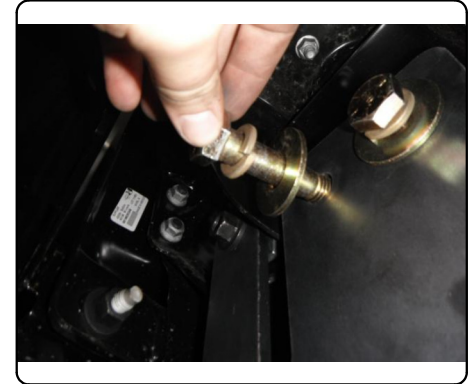

7. Reposition and level bumper by pushing up on it while tightening the hardware. Torque 5/8" hardware to 210 ft-lbs and M12 hardware to 86 ft-lbs.



31067

RAM 3500

7/26/2013

GROSS LOAD CAPACITY WHEN USED AS A WEIGHT CARRYING HITCH: 5,000 LBS. TRAILER WEIGHT & 500 LBS. TONGUE WEIGHT.
 GROSS LOAD CAPACITY WHEN USED AS A STRAIGHT LINE PULL: 9,000 LBS. MAX. LINE PULL.
***** DO NOT EXCEED VEHICLE MANUFACTURER'S RECOMMENDED TOWING CAPACITY. *****
 HAVING INSTALLATION QUESTIONS? CALL TECHNICAL SUPPORT AT 1-800-798-0813

		Parts List	
ITEM	QTY	PART NUMBER	DESCRIPTION
1	4	5_8 - 11 x 4 HEX	HEX BOLT
2	4	5_8 LOCK WASHER	LOCK WASHER
3	4	5/8"	WASHER WIDE
4	4	5/8-11	HEX FLANGE NUT
5	2	CM-SP42	.250 x 2.00 x 2.00" ROUND HOLE SPACER
6	2	31067-SP	SPACER PLATE .500" A-36 H.R. (1020)

TOOLS REQUIRED	
RATCHET	
18mm & 15/16" SOCKETS	
15/16" END WRENCH	
ROTARY TOOL	
CUT WHEEL	
SAFETY GLASSES	
MARKER	
TAPE MEASURE	
TORQUE WRENCH	

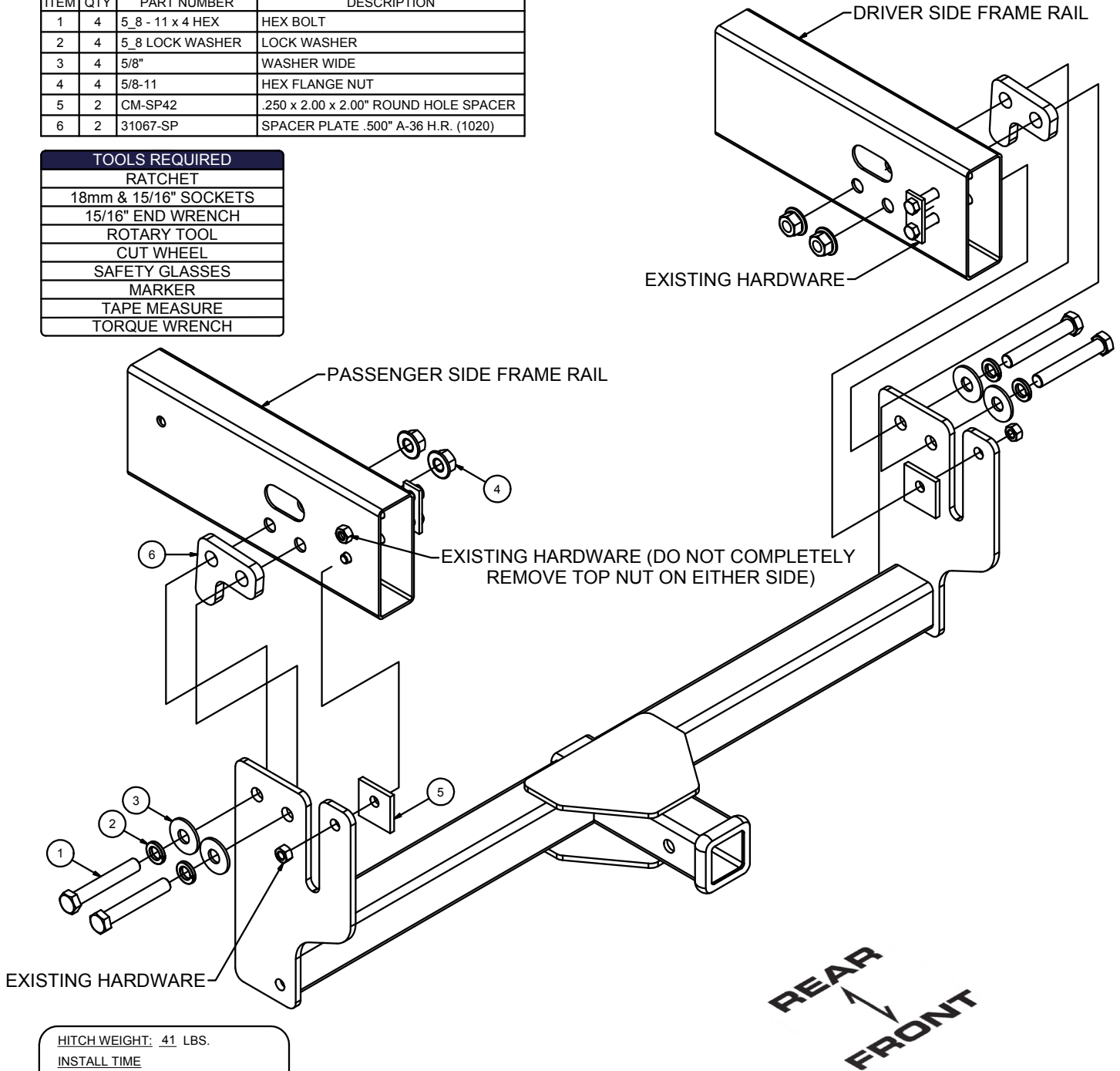

HITCH WEIGHT: 41 LBS.
 INSTALL TIME
 PROFESSIONAL: 30 MINUTES
 NOVICE (DIY): 60 MINUTES
 INSTALL NOTES:
 - NO DRILLING REQUIRED
 - AIR DAM TRIMMING REQUIRED

PERIODICALLY CHECK THIS RECEIVER HITCH TO ENSURE THAT ALL FASTENERS ARE TIGHT AND THAT ALL STRUCTURAL COMPONENTS ARE SOUND.

Curt Manufacturing LLC., warrants this product to be free of defects in material and/or workmanship at the time of retail purchase by the original purchaser. If the product is found to be defective, Curt Manufacturing LLC., may repair or replace the product, at their option, when the product is returned, prepaid, with proof of purchase. Alteration to, misuse of, or improper installation of this product voids the warranty. Curt Manufacturing LLC.'s liability is limited to repair or replacement of products found to be defective, and specifically excludes liability for incidental or consequential loss or damage.

31067

RAM 3500

GROSS LOAD CAPACITY WHEN USED AS A WEIGHT CARRYING HITCH: 5,000 LBS. TRAILER WEIGHT & 500 LBS. TONGUE WEIGHT.
GROSS LOAD CAPACITY WHEN USED AS A STRAIGHT LINE PULL: 9,000 LBS. MAX. LINE PULL.
***** DO NOT EXCEED VEHICLE MANUFACTURER'S RECOMMENDED TOWING CAPACITY. *****
HAVING INSTALLATION QUESTIONS? CALL TECHNICAL SUPPORT AT 1-800-798-0813

TRIM DIAGRAM

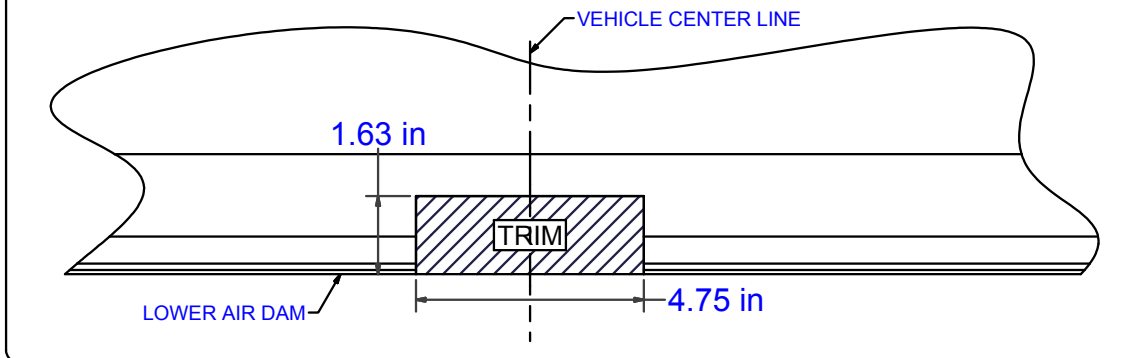

INSTALLATION STEPS

1. Trim lower air dam as needed for hitch, see trim diagram above for approximate trim location.
2. Remove / loosen four existing nuts from behind the bumper, as shown on page 1. Remove the lower two nuts on each side, these lower two bolts are used to mount the hitch. Loosen the top nut on each side until only a couple threads are engaged. The top nut will prevent the bolts from being pushed completely through. Push both sets of bolts towards the center of the vehicle.
Note: Loosening these bolts will cause the bumper to shift down slightly. Pushing up on the bumper may take pressure off the bolts making them easier to move. If needed, use a soft mallet to tap the bolts in. The passenger side bolts may not go in as far in as the driver side bolts. **Complete removal of all four bolts will cause the bumper to fall.**
3. Place one CM-SP42 spacer (5) onto the exposed bolt on each side.
4. Raise the hitch into position by first raising the passenger side of the hitch and inserting the bolts back into position through the forward most hole in the hitch side plate. Rotate the driver side of the hitch up into position and push the bolts back towards the outside of the vehicle.
5. Insert spacer plate (6) between the frame and hitch side plate. Insert two 5/8" x 4" hex bolts (1) with a lock washer (2) and washer (3) on each. Insert in through the side plate / spacer and out the frame, as shown on page 1. Attach using two 5/8" hex flange nuts (4) and repeat on the other side.
6. Reposition and level bumper by pushing up on it while tightening the hardware. Torque 5/8" hardware to 210 ft-lbs and M12 hardware to 86 ft-lbs.

PERIODICALLY CHECK THIS RECEIVER HITCH TO ENSURE THAT ALL FASTENERS ARE TIGHT AND THAT ALL STRUCTURAL COMPONENTS ARE SOUND.

Curt Manufacturing LLC., warrants this product to be free of defects in material and/or workmanship at the time of retail purchase by the original purchaser. If the product is found to be defective, Curt Manufacturing LLC., may repair or replace the product, at their option, when the product is returned, prepaid, with proof of purchase. Alteration to, misuse of, or improper installation of this product voids the warranty. Curt Manufacturing LLC.'s liability is limited to repair or replacement of products found to be defective, and specifically excludes liability for incidental or consequential loss or damage.

*****DO NOT EXCEED VEHICLE MANUFACTURER'S RECOMMENDED TOWING CAPACITY*****.

FRONT MOUNTED ACCESSORIES

1) Do not exceed front axle Gross Weight Rating (GAWR). Consult owners manual or specification plate located on driver's door frame. Measure gross front axle weight by placing front wheels of loaded vehicle on a scale.

WARNING: Exceeding GAWR may overload the front axle and/or suspension. This could result in **accident, property damage and personal injury.**

- 2) Reposition front mounted license plate if obstructed.
- 3) Do not obstruct vehicle lights.
- 4) Allow free air flow into grille opening.
- 5) Rear wheel traction may be reduced. This could effect handling. Reduce speed and drive with caution.
- 6) Accessories extend front of vehicle. This may reduce approach angle. Use caution when parking and maneuvering.
- 7) Do not obstruct driver view.

VEHICLE RECOVERY AND WINCHING TIPS

1) Use OEM tow hooks, recovery eyes or a clevis mount for attachment of a tow strap or winch cable.

WARNING: NEVER use a ball and/or ball mount as an anchor point for tow strap or winch cable. Severe personal injury or death could result.

- 2) Observe winch manufacturer's recommendations, cautions and warnings.
- 3) Attach return cable to tow hook or recovery eye when using a snatch block (See figure 1).

CAUTION: Do not attach return cable to winch mount. This may overload winch mount and/or front mounted receiver.

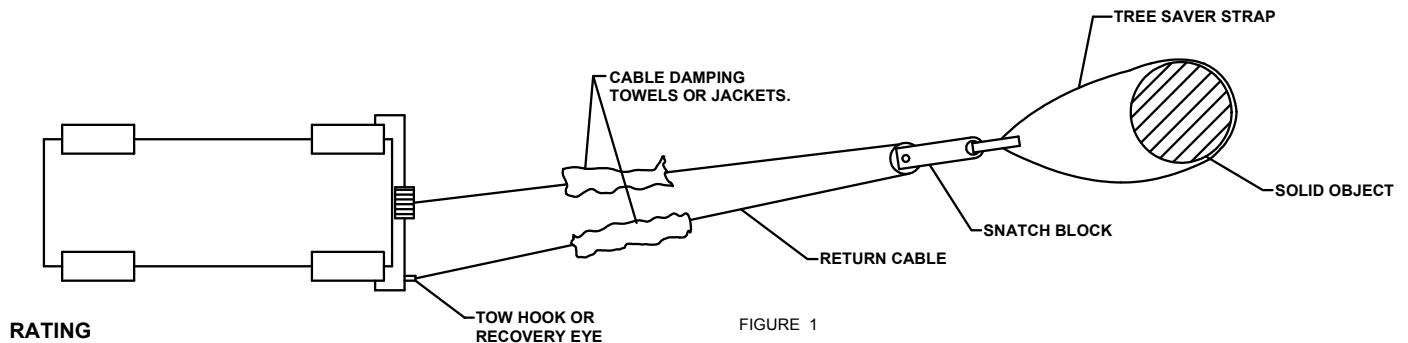

RATING

For **Maximum** line pull rating, winch cable must not exceed:

- 15 degree angle up or down from horizontal (See Figure 2).
- 45 degree angle left or right from straight ahead (See Figure 3).

CAUTION: Exceeding the maximum line pull rating may over load winch, winch mount, and/or front mounted receiver.

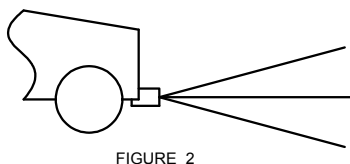

FIGURE 2

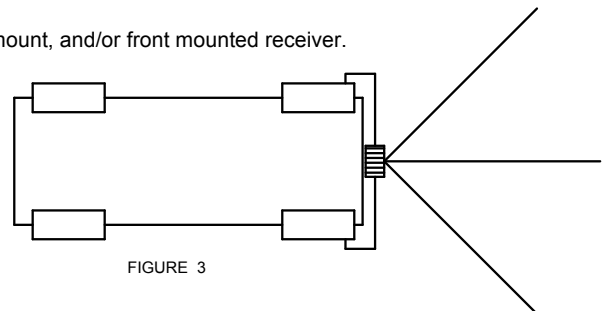

FIGURE 3